



# DHD 72K CRANE BODY

Minimum 33,000 Lb. G.V.W.R. Medium Duty Chassis

DHD						
SPECIFICATIONS	DHD 84	DHD 108	DHD 120	DHD 84 HI-Cube	DHD 108 HI-Cube	DHD 120 HI-Cube
Body Length	131"	155"	167"	131"	155"	167"
Overall Width	98.5"	98.5"	98.5"	98.5"	98.5"	98.5"
Front Height	48"	48."	48"	60"	60"	60"
Rear Height	45"	45"	45"	57"	57"	57"
Floor Width	52"	52"	52"	50"	50"	50"
Compartment Depth	22"	22"	22"	23"	23"	23"
Floor to top of Compartment	23"	23"	23"	35"	35"	35"
Front Compartment Length	38"	38"	38"	57" LH; 38" RH	57" LH; 38" RH	57" LH; 38" RH
Second Compartment Length	18"	24"	28"	N/A LH; 19" RH	N/A LH; 24" RH	N/A LH; 28" RH
Third Compartment Length	N/A	18"	26"	N/A	24" LH; 19" RH	36" LH; 27" RH
Horizontal Compartment Length	51"	51"	51"	51"	51"	51"
Rear Compartment Length	24"	24"	24"	24"	24"	24"
Optional Oxy/Ace Compartment Height	60"	60"	60"	60"	60"	60"
Approximate Base Body Weight	4040	4605	4900	6020	6990	7385

\*\* DHD 72K Chassis Requirements : 33,000 Lbs.  
G. V. W. R. Required Minimum. See Crane Mfg.  
Chassis Requirements Also.

**Our Promise To You:**  
" No Compromise"  
in Providing the  
Very Best Equipment  
Available!



DHD 84 72K CB with O/A and Tailshelf Option

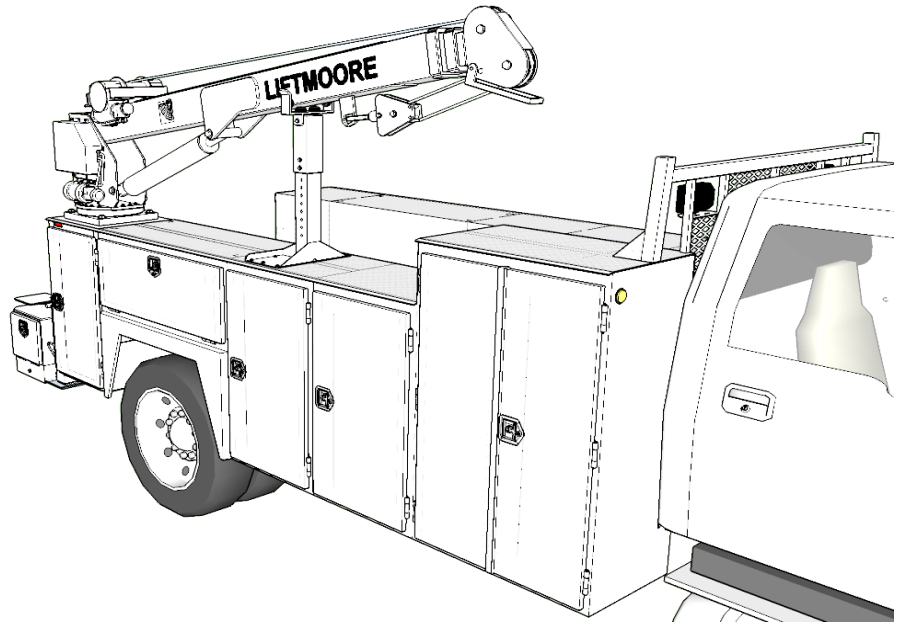

DHD 120 72K CB

For Standard Features and Options See Reverse Side

## STANDARD FEATURES 72K MODELS

- \* **Body Subframe: 3X8X3/8 & 8X3/16 Crossmembers, 10 Ga Longitudinal Floor Reinforcement**
- \* **3/8" Rear & 1/4 Front Torsion Box Subframe for Rigidity**
- \* **Low Floor Height (Only 6" above Chassis Frame)**
- \* **Floor: 1/8" Treadplate**
- \* **Compartment Tops and Rears: 1/8" Treadplate**
- \* **Crane Compartment: 1/2" H.R. Steel with 3/4" H.R. Top Plate and 4X3X 1/2" angle reinforcement. Completely open for Storage**
- \* **Major Body Components: 12 Ga. and 10 Ga. H.R.P.O.**
- \* **Body Designed With Appropriate Material Eliminating Overlays with Rust Pockets**
- \* **Superior Weather Tight Double Panel Galvaneal Doors Automotive Type Replaceable Bulb Rubber Seals Over Center Spring Loaded Door Restraints Stainless Steel 3 Point Locking T-Handle Latches Greaseable XHD Hinges with 5/16" Stainless Steel Pins.**
- \* **Spring Mounting Kit**
- \* **22" Deep Compartments**
- \* **12 Gauge Formed Tailgate/ Work Table**
- \* **Die Formed Ribs in Front Bulk Head**
- \* **Recessed Cargo Tie Down Rings**
- \* **All exterior Welds are Continuous Fully Penetrating Welds. No Caulking is used on these bodies.**
- \* **HD Shelf Support Channels that hold the shelf where You put it even on the Roughest Road**
- \* **Anti - Rattle Shelf Dividers**
- \* **A Factory Installed Wiring Loom is Provided with each Crane Body**
- \* **Stop, Turn, Tail Lights are Sealed Beams**
- \* **Each Crane Body is Thoroughly Cleaned and Phosphatized Prior to the Application of 2 Mills of PPG Plural Component Epoxy Primer**

## OPTIONAL EQUIPMENT ALL MODELS

- \* **Drawer Storage Units Mounted on 300 lb. Accuride Slides available for any compartment.**
- \* **A 600 lb. Slide out Mechanics Tool Trey**
- \* **Literature Drawer**
- \* **Material Storage Hooks for storage of Ropes, Cables, Cords, etc. These are available in Fixed, Swivel, and Sliding Swivel arrangements.**
- \* **60" Tall Vented Oxygen / Acetylene Storage Compartment available in D - 1 or P - 1. The Compartment comes complete with Reinforced Floor with Bottle Retention Rings, Bottle Tie Downs, Gauge and Torch Holders, and a Hose Rack.**
- \* **Oxygen / Acetylene compartment with vertical partition and 4 small adjustable shelves**
- \* **Additional Adjustable Shelves and Dividers**
- \* **Egg Crate Fastener Storage Drawer available in either Horizontal Compartment**
- \* **Theft Deterrent Master Locking System**
- \* **Cushioned Adjustable Boom Rest (shipped loose)**
- \* **Hydraulic Crane Prep Package**
- \* **Compartment Lights**
- \* **HD Step Bumper**
- \* **HD Step Bumper with Recessed 2" Ball Plate**
- \* **HD Step Bumper with Recessed Pintle Hitch Plate**
- \* **HD Step Bumper with Manual Out and Down Outriggers with Spring Retract Legs.**
- \* **HD Step Bumper with Manual Out and Down Outriggers with Spring Retract Legs with Tailshelf and Thru Compartment**
- \* **Hyd. Outrigger/Work Platform/Through Comp.**
- \* **Header with Work Light Brackets (no lights)**

Authorized Distributor :

**Outriggers Must Be Used On All Models  
When Operating Crane !**

For the name of your nearest  
Dutec distributor call  
903-868-1917

  
Sherman, Texas