



DSD SB

DSD	MODEL	MODEL
SPECIFICATIONS	DSD 60 SB	DSD 84 SB
Body Length	109	133"
Overall Width	96"	96"
Front Height	46"	46"
Rear Height	43"	43"
Floor Width	49.5"	49.5"
Compartment Depth	22"	22"
Floor to top of Compartment	25"	25"
Front Compartment Length	35"	38"
Second Compartment Length	-	21"
Horizontal Compartment Length	48"	48"
Rear Compartment Length	26"	26"
Approximate Base Body Weight w O. A.	1898	2206
Standard Shelving Package Weight	257	323

**Our Promise To You:
" No Compromise"
in Providing the
Very Best Equipment
Available**

**** DSD Chassis Requirements : 13,000 - 19,500 Lbs. G.V.W.R.
Minimum For Body And Chassis Only. Does Not Address Chassis
Limitations Imposed By Crane Manufacturer.**

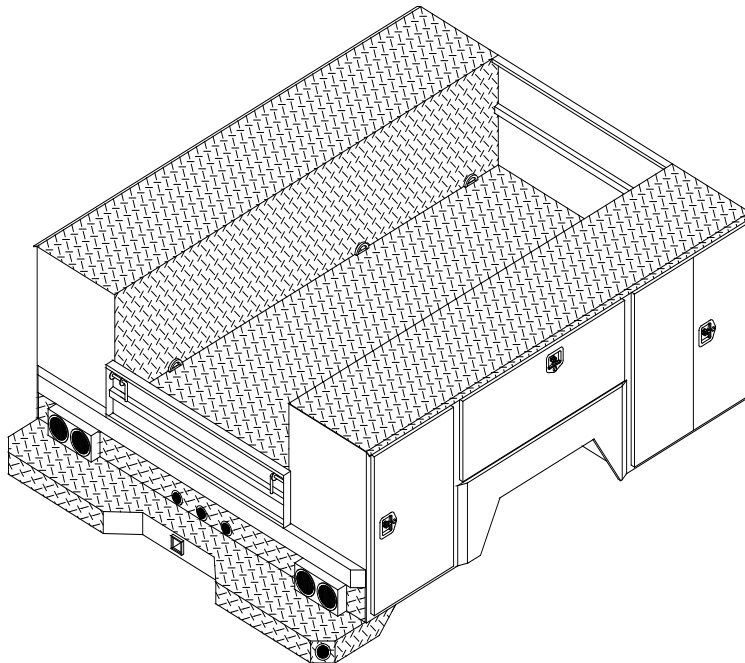

DSD 60 SB Shown

SB SERVICE BODY STANDARD FEATURES

- * Body Subframe: 5" X 3/16 HR Gauge Crossmembers with Longitudinal Floor Reinforcement and Torsion Box Subframe for Body Rigidity
- * Low Floor Height (Only 5" above Chassis Frame)
- * Floor: 1/8" Treadplate
- * Compartment Tops and Rears: 1/8" Treadplate
- * Major Body Components: 12 Ga. and 10 Ga. H.R.P.O.
- * Body Designed With Appropriate Material Eliminating Overlays with Rust Pockets
- * Superior Weather Tight Double Panel Galvaneal Doors
- * Automotive Type Replaceable Bulb Rubber Seals
- * 14 Gauge Shelving Package with Dividers
- * HD Shelf Support Channels that hold the shelf where you put it even on the roughest road
- * Anti - Rattle Shelf Dividers
- * Spring Mounting Kit
- * 22" Deep Compartments
- * 12 Gauge Formed Tailgate/ Work Table
- * Over Center Spring Loaded Door Restraints
- * Stainless Steel 3 Point Locking T-Handle Latches
- * Greaseable XHD Hinges with 5/16" Stainless Steel Pins.
- * Die Formed Ribs in Front Bulk Head
- * Recessed Cargo Tie Down Rings
- * All exterior Welds are Continuous Fully Penetrating Welds.
No Caulking is used on these bodies.
- * A Factory Installed Wiring Loom is Provided with each body
- * Stop, Turn, Tail Lights are Sealed Beams
- * Bodies are Thoroughly Cleaned and Phosphatized Prior to the Application of 2 Mils of PPG Plural Component Epoxy Primer

OPTIONAL SB SERVICE BODY EQUIPMENT

- * Drawer Storage Units Mounted on 300 lb. Accuride Slides available for any compartment.
- * A 600 lb. Slide out Mechanics Tool Tray
- * Material Storage Hooks for storage of Ropes, Cables, Cords, etc. These are available in Fixed, Swivel, and Sliding Swivel arrangements.
- * 60" Tall Vented Oxygen / Acetylene Storage Compartment available in D - 1 or P - 1. The Compartment comes complete with Reinforced Floor with Bottle Retention Rings, Bottle Tie Downs, Gauge and Torch Holders, and a Hose Rack.
- * Oxygen / Acetylene compartment with vertical partition and 4 small adjustable shelves
- * Additional Adjustable Shelves and Dividers
- * Egg Crate Fastener Storage Drawer available in either Horizontal Compartment
- * Theft Deterrent Master Locking System
- * Hydraulic Crane Prep Package
- * Compartment Lights
- * HD Step Bumper with Hitch Receiver
- * Louvered Header

Authorized Distributor :

Outriggers Must Be Used On All Models
When Operating Crane !

For the name of your nearest
Dutec distributor call
903-868-1917

