



DHD SERVICE BODY

Minimum 20,000 Lb. G.V.W.R. Medium Duty Chassis

DHD SPECIFICATIONS	MODEL		
	DHD 84	DHD 108	DHD 120
Body Length	131"	155"	167"
Overall Width	98.5"	98.5"	98.5"
Front Height	48"	48"	48"
Rear Height	45"	45"	45"
Floor Width	52"	52"	52"
Compartment Depth	22"	22"	22"
Floor to top of Compartment	25"	25"	25"
Front Compartment Length	38"	38"	38"
Second Compartment Length	18"	24"	28"
Third Compartment Length	N/A	18"	26"
Horizontal Compartment Length	51"	51"	51"
Rear Compartment Length	24"	24"	24"
Optional Oxy/Ace Compartment Height	60"	60"	60"
Approximate Base Body Weight	3040	3605	3900

Our Promise To You:
"No Compromise"
 in Providing the
Very Best Equipment
Available!

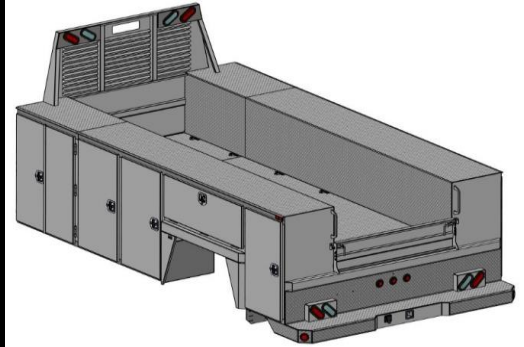

**DHD 120 SB
BASE BODY**

** DHD Chassis Requirements : 20,000 Lbs. G.V.W.R. Required Minimum

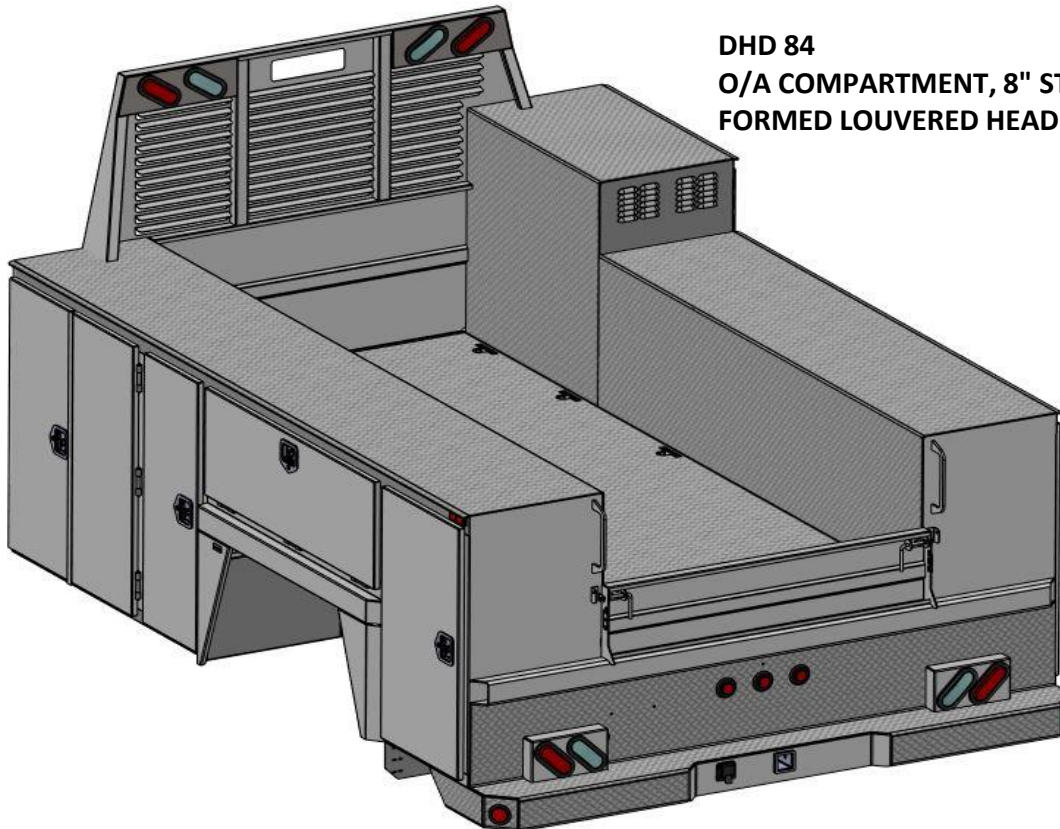

**DHD 84
O/A COMPARTMENT, 8" STEP BUMPER,
FORMED LOUVERED HEADER**

For Standard Features and Options See Reverse Side

STANDARD FEATURES for DHD SB MODELS

- * **Body Subframe: 6" X 3/16" Crossmembers,**
- * **10 Ga Longitudinal Floor Reinforcement**
- * **3/16" Torsion Box Subframe for Rigidity**
- * **Low Floor Height (6" above Chassis Frame)**
- * **Floor: 1/8" Treadplate**
- * **Compartment Tops and Rears: 1/8" Treadplate**
- * **All exterior Welds are Continuous & Fully Penetrating Welds.**
- * **Major Body Panels: 12 Ga. and 10 Ga. H.R.P.O.**
- * **Body Designed With Appropriate Material Eliminating Overlays with Rust Pockets**
- * **Weather-Tight Double Panel Galvn. Doors Auto Type Replaceable Bulb Rubber Seals**
- * **Over Center Spring Loaded Door Restraints**
- * **Stainless Steel 3 Point Locking T-Handle Latches**
- * **Greaseable XHD Hinges with 5/16" SS Pins.**
- * **Spring Mounting Kit**
- * **22" Deep Compartments**
- * **12 Gauge Formed Tailgate/ Work Table**
- * **Die Formed Ribs in Front Bulk Head**
- * **Recessed Cargo Tie Down Rings**
No Caulking is used on these bodies.
- * **HD Shelf Support Struts that hold the shelf where you put it even on the Roughest Road**
- * **Anti - Rattle Shelf Dividers**
- * **A Factory Installed Wiring Loom is Provided with each Crane Body**
- * **Stop, Turn, Tail Lights are LED Sealed Beams**
- * **Each Crane Body is Thoroughly Cleaned and Phosphatized Prior to the Application of 2 mils of PPG Plural Component Epoxy Primer**

OPTIONAL EQUIPMENT ALL MODELS

- * **Drawer Storage Units Mounted on 300 lb. Accuride Slides available for any compartment.**
- * **A 600 lb. Slide out Mechanics Tool Tray**
- * **Material Storage Hooks for storage of Ropes, Cables, Cords, etc. These are available in Fixed, Swivel, and Sliding Swivel arrangements.**
- * **60" Tall Vented Oxygen / Acetylene Storage Compartment available in D - 1 or P - 1. The Compartment comes complete with Reinforced Floor with Bottle Retention Rings, Bottle Tie Downs, Gauge and Torch Holders, and a Hose Rack.**
- * **Oxygen / Acetylene compartment with vertical partition and 4 small adjustable shelves**
- * **Additional Adjustable Shelves and Dividers**
- * **Theft Deterrent Master Locking System**
- * **Cushioned Adj. Boom Rest (shipped loose)**
- * **Hydraulic Crane Prep Package**
- * **Compartment Lights**
- * **HD Step Bumper**
- * **HD Step Bumper w/Recessed Pintle Hitch Plate**
- * **Tubing Header with Work Light Bkts.**
- * **Louvered Header with Work Lights**
- * **Louvered Header with STT/BU Lights**

Authorized Distributor :

For the name of your nearest
Dutec distributor call
903-868-1917

