



Winch Body

MODEL SELECTION CHART

MODEL	O.A. LENGTH	O.A DECK LENGTH	O.A. WIDTH	LONG SILL SIZE	APPROX. WEIGHT
D 460 - 9	108"	103.5"	96"	5"	2032 #
D 484 - 11	132"	128"	96"	5"	2321 #
D 584	124 1/2"	94"	96"	6"	2907 #
D 5102	142 1/2"	112"	96"	6"	3209 #
D 5108	148 1/2"	118"	96"	6"	3262 #
D 5120	160 1/2"	129.875"	96"	6"	3446 #
D 5120E	175 3/8"	144.75"	96"	6"	3694 #
D 5138E	193.375"	162.75"	96"	6"	4022 #

* O.A. Length is overall length from front of the longsills to end of tail roller

Our Promise to You:

"No Compromise" in Providing the Best Equipment Available !

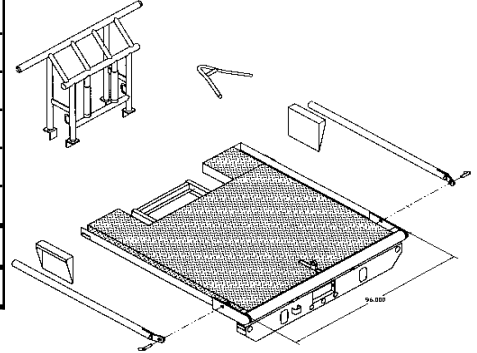

400 Series

Winch body package includes:

- * Longsills - made of structural channel
- * Crossmembers - 3/16" on 12" or 14" centers notched to support pole.
- * Folding Toggle Block - 2 1/2" X 1" recessed in reinforced pocket
- * Winch Brackets - Formed 1/4" with gussets each end and reinforced top plate
- * A - Frame - 1 3/8" Formed round
- * Tail Section - Full skirted 400: 1/4" 500: 3/8" plate
- * Floor - 3/16" Tread plate
- * Rear Floor - 1/4" Smooth plate (500 Series Only)
- * Poles - Schedule 80 pipe
- * Oilfield Headache Rack - Schedule 80 pipe
- * Tail Roller - Schedule 80 pipe with full length center shaft. With 5 internal support donuts, HD bearings with protected grease fittings and 3/4" X 8" end plates
- * Tail Roller Load Supports - 2 dual rollers . with grease fittings. Load is supported in downward and forward directions adding substantial protection to tail roller from extremely heavy loads and shock loads.
- * Lighting - Protected DOT LED lighting package and factory wiring harness.

OPTIONS:

- * Anti - theft chain and boomer racks with catch pan 1/2", or 5/16" & 3/8" Chain

Authorized Distributor:



For the name of your nearest DuTec distributor call 903-868-1917



Sherman, Texas

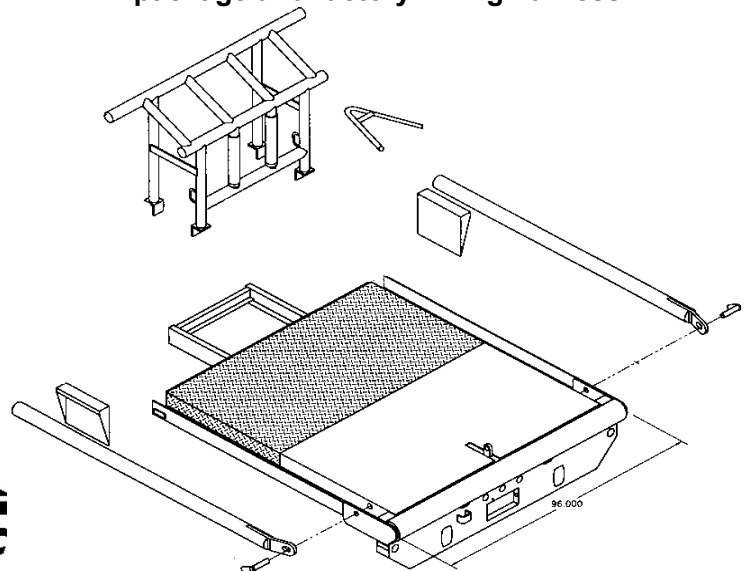

500 Series